



US 20180078780A1

(19) **United States**

(12) **Patent Application Publication**

Sun et al.

(10) **Pub. No.: US 2018/0078780 A1**

(43) **Pub. Date: Mar. 22, 2018**

(54) **TIME-VARYING MAGNETIC FIELD THERAPY USING MULTISTABLE LATCHING MECHANISMS**

**Publication Classification**

(51) **Int. Cl.**  
*A61N 2/12* (2006.01)  
*H01F 7/02* (2006.01)  
*A61N 2/00* (2006.01)

(52) **U.S. Cl.**  
 CPC ..... *A61N 2/12* (2013.01); *A61N 2/006* (2013.01); *H01F 7/0221* (2013.01); *H01F 7/0273* (2013.01)

(71) Applicant: **Rhode Island Board of Education, State of Rhode Island and Providence Plantations, Providence, RI (US)**

(72) Inventors: **Ying Sun, West Warwick, RI (US); Brian Silver, Sharon, MA (US); Tanya Wang, Cranston, RI (US)**

(21) Appl. No.: **15/708,333**

(22) Filed: **Sep. 19, 2017**

**Related U.S. Application Data**

(60) Provisional application No. 62/396,915, filed on Sep. 20, 2016.

(57) **ABSTRACT**

The invention provides wearable devices for effecting transcranial magnetic stimulation to be used by patients who have suffered brain injuries. Permanent magnets are shifted or rotated to deliver a time-varying magnetic field, preferably about the locus of the injury. In a preferred embodiment, the strong magnetic fields of the permanent magnets are directed to the injured area for therapeutic purposes. A novel mechanism is provided that uses a small battery-powered electromagnet to interact with the weak peripheral magnetic fields of the permanent magnets and to shift the permanent magnets between two or more stable positions. As a result, a lightweight, quiet, wearable device with low power consumption is provided.

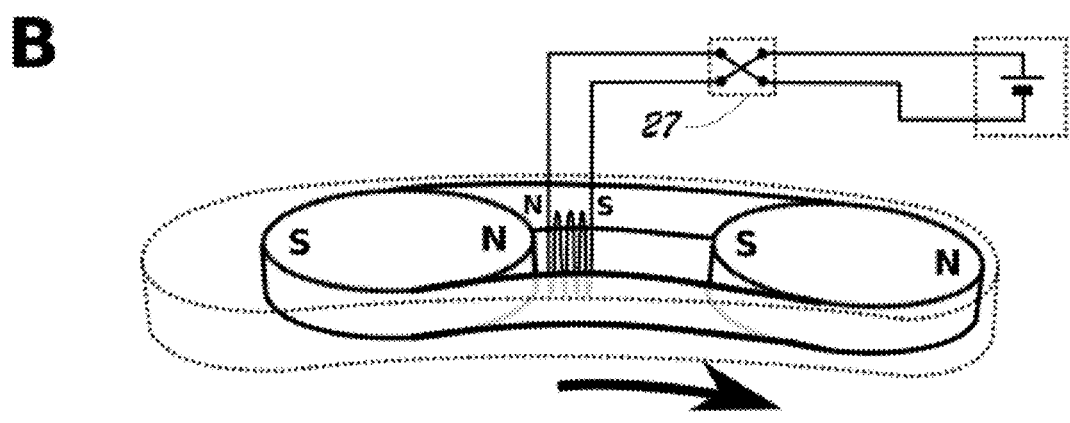
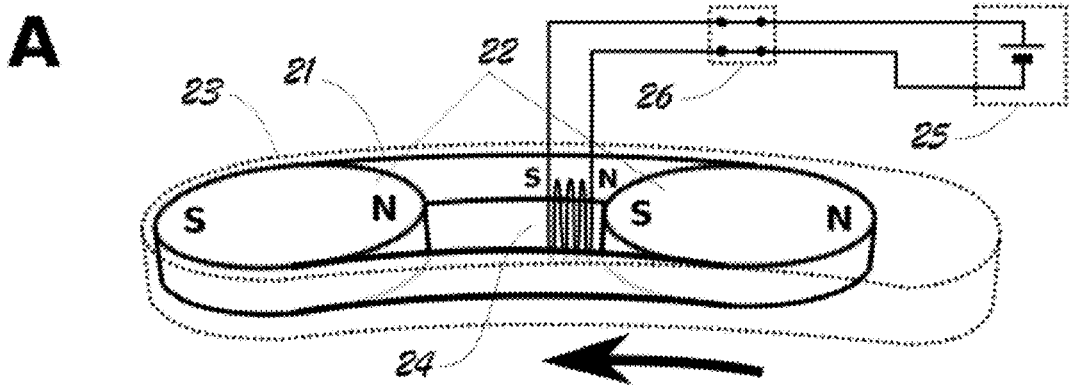

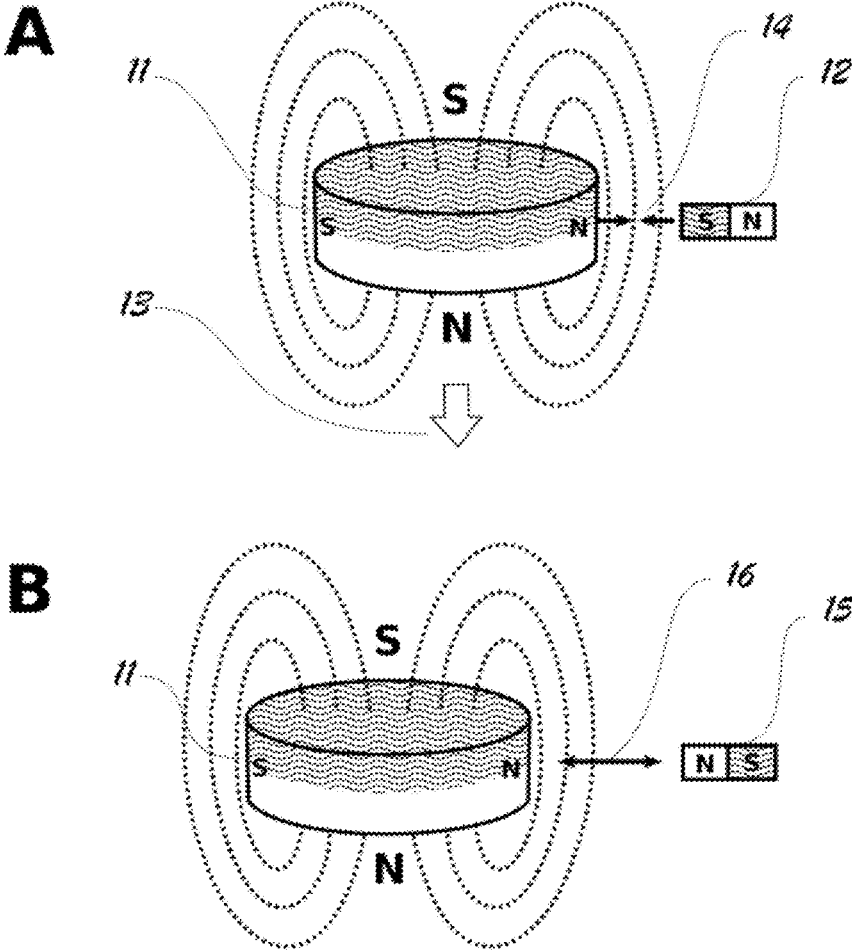

FIG. 1

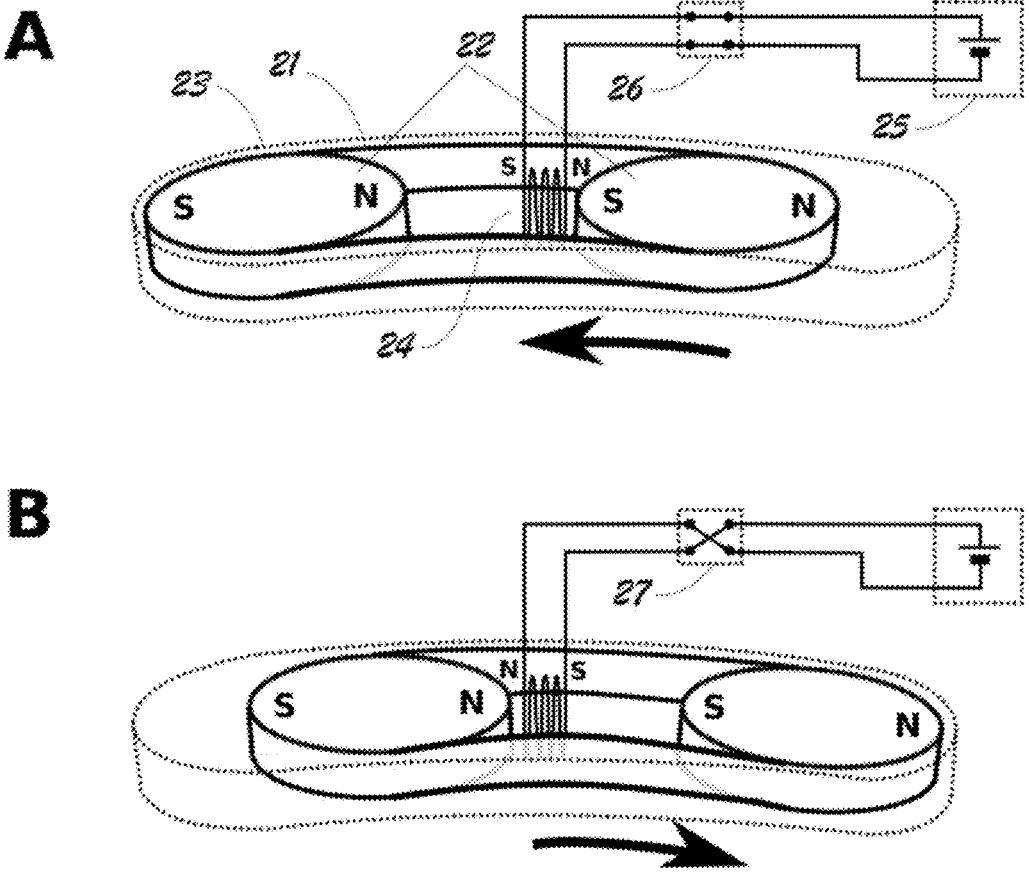

FIG. 2

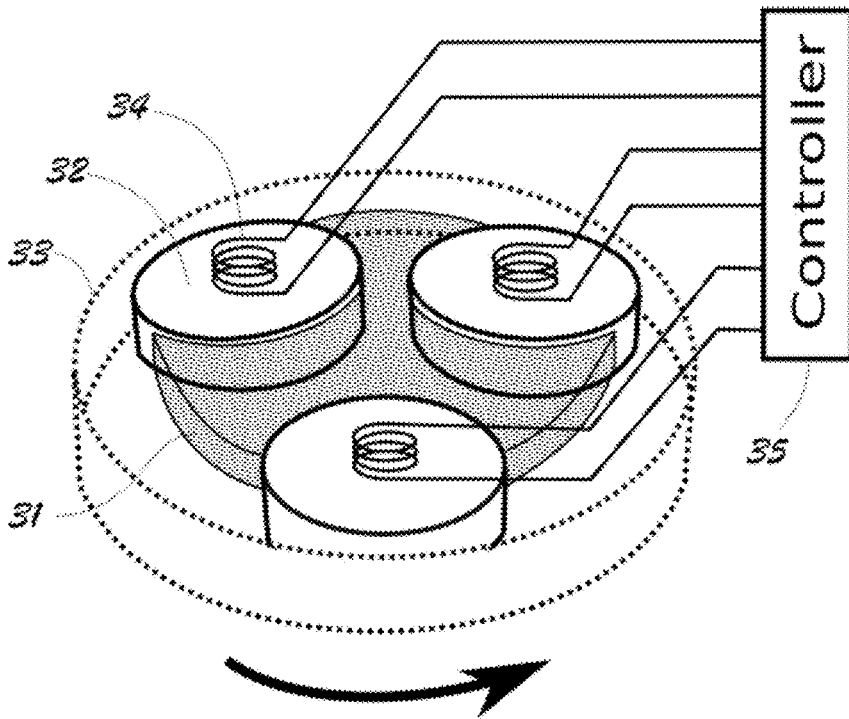

FIG. 3

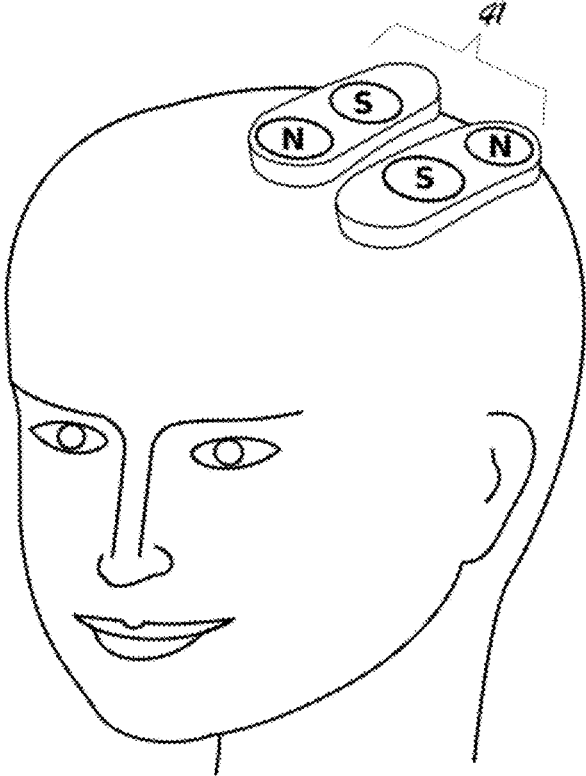

FIG. 4

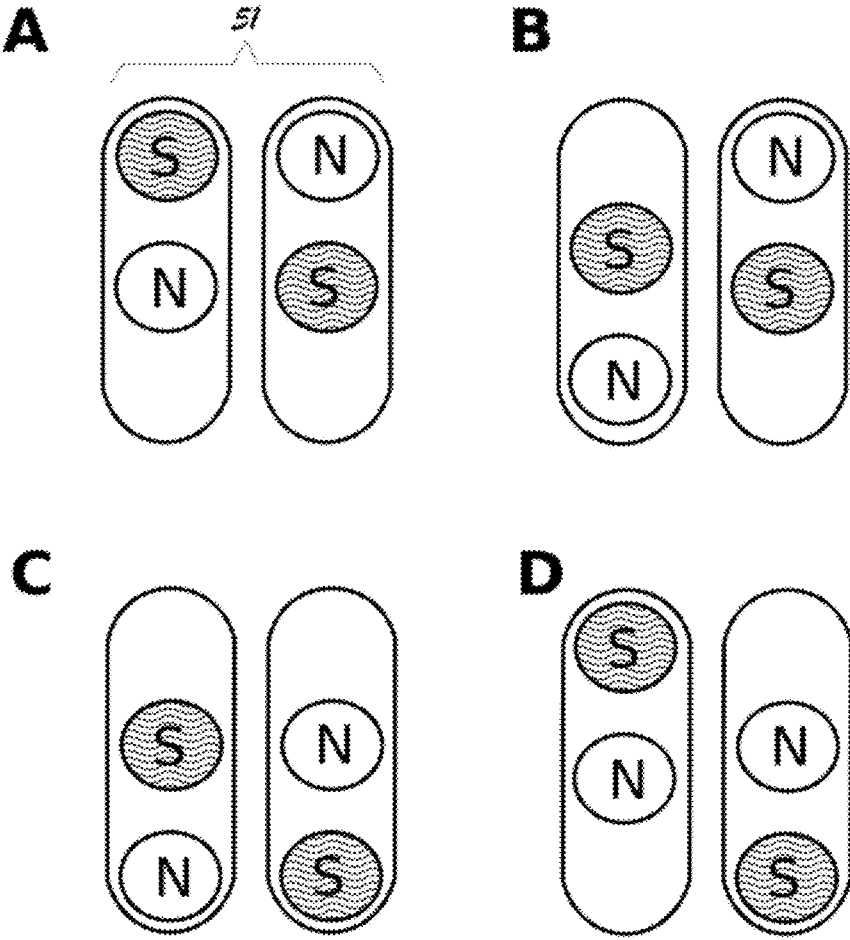

FIG. 5

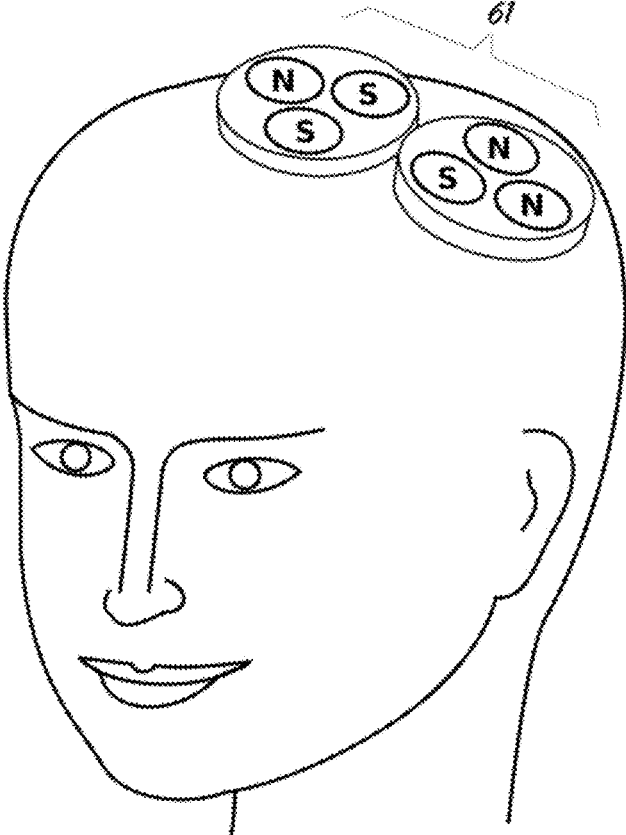

FIG. 6

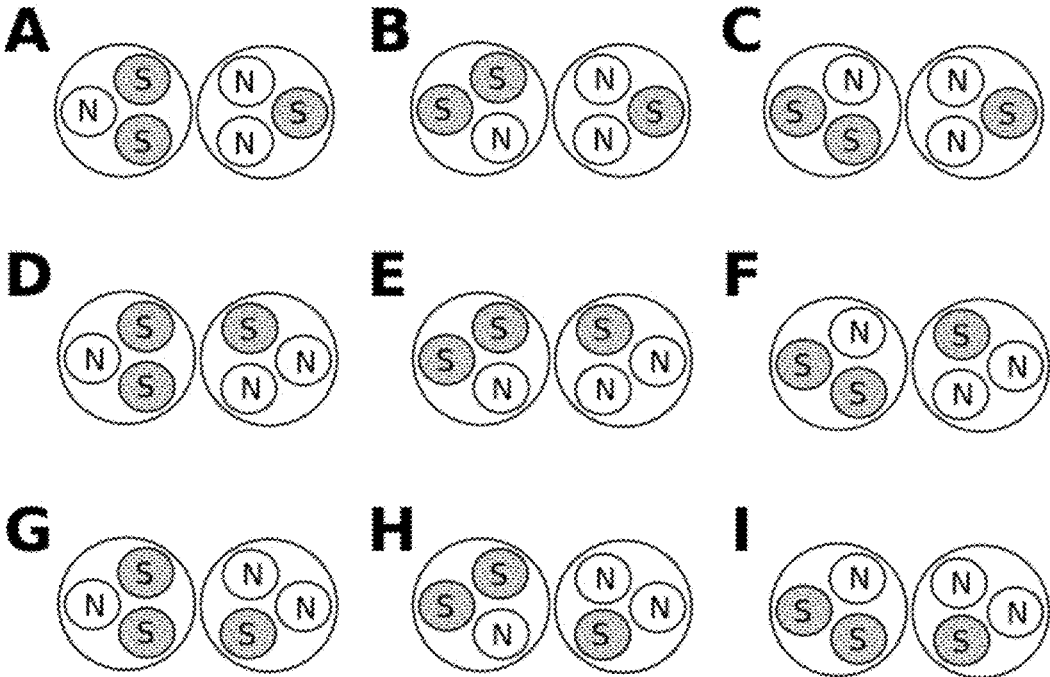

FIG. 7



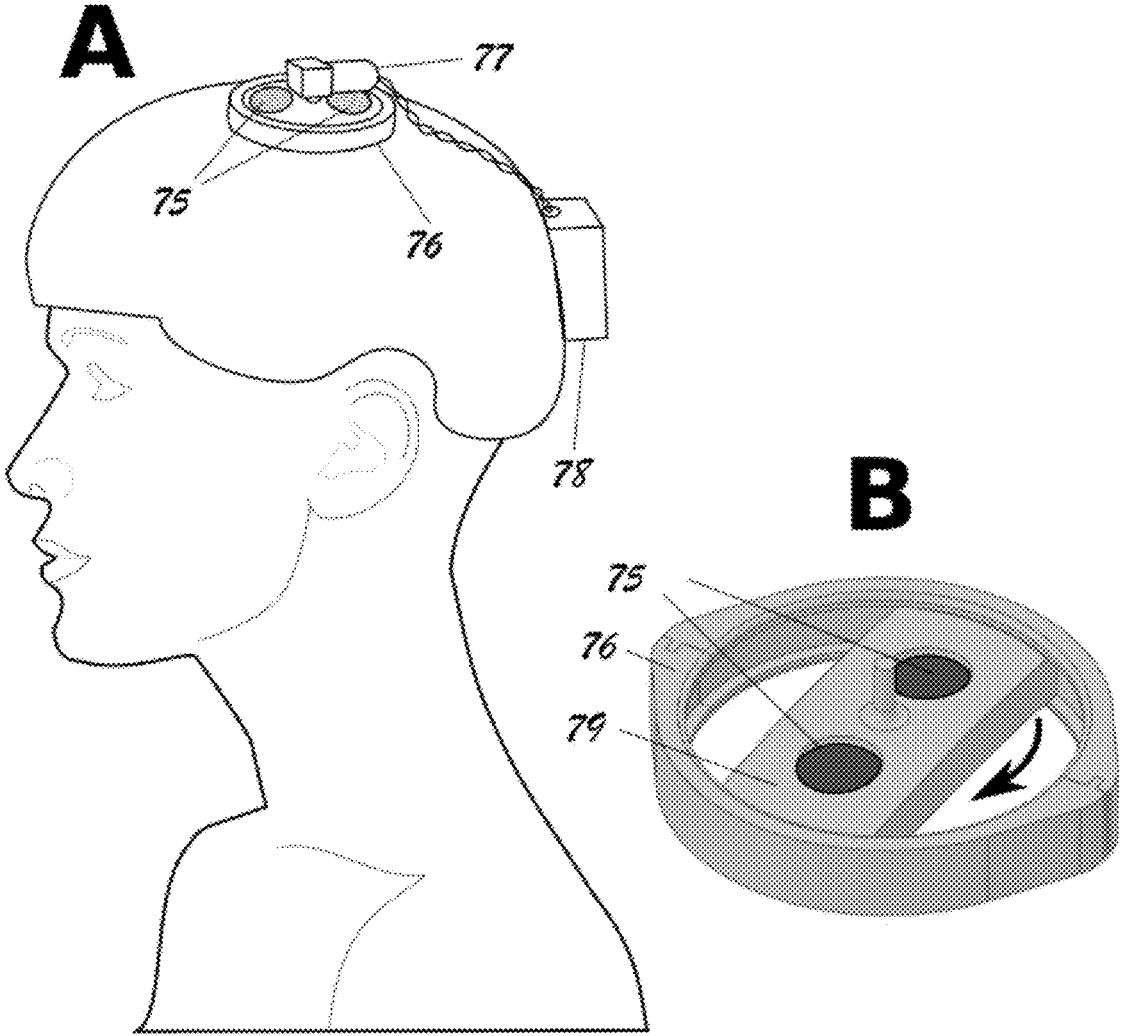

FIG. 8A

FIG. 8B

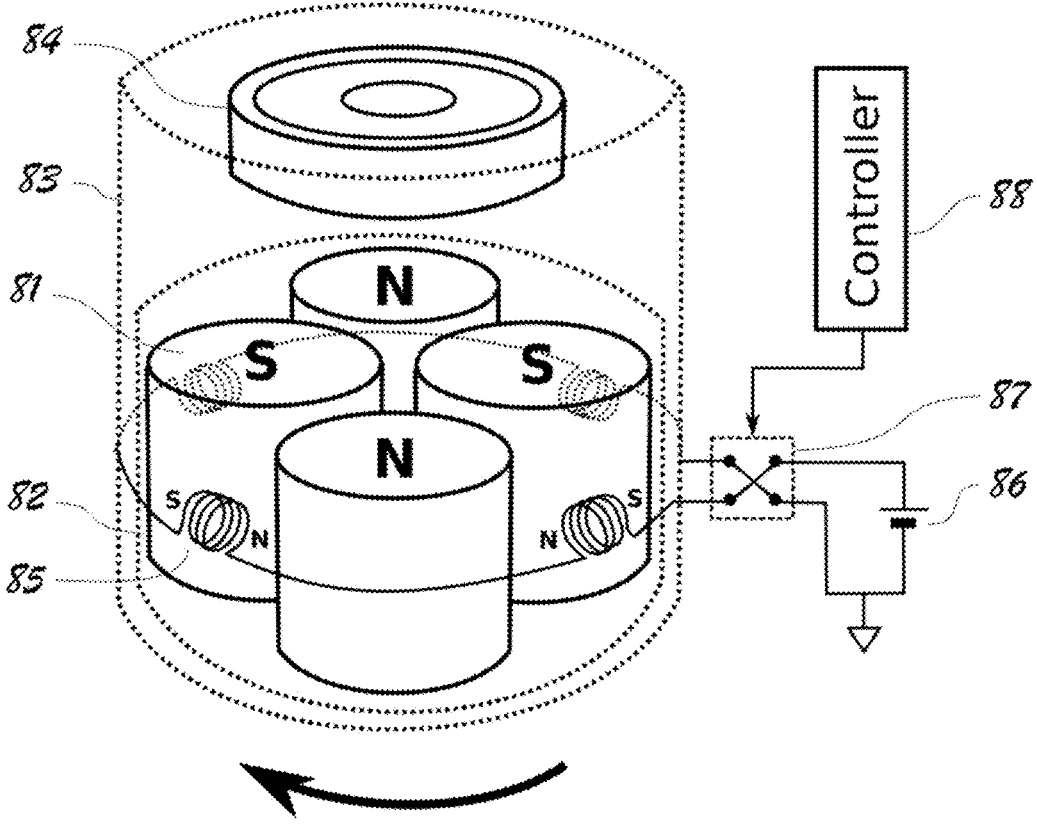

FIG. 9

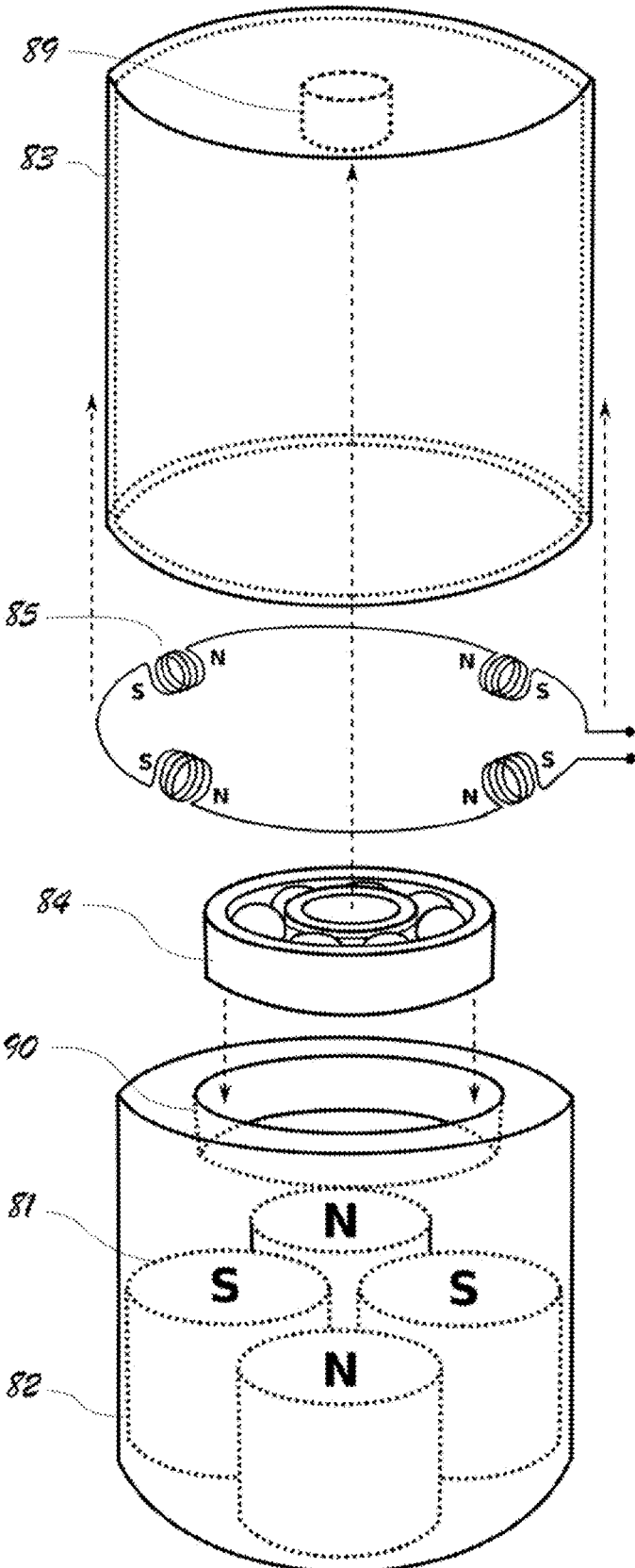

FIG. 10

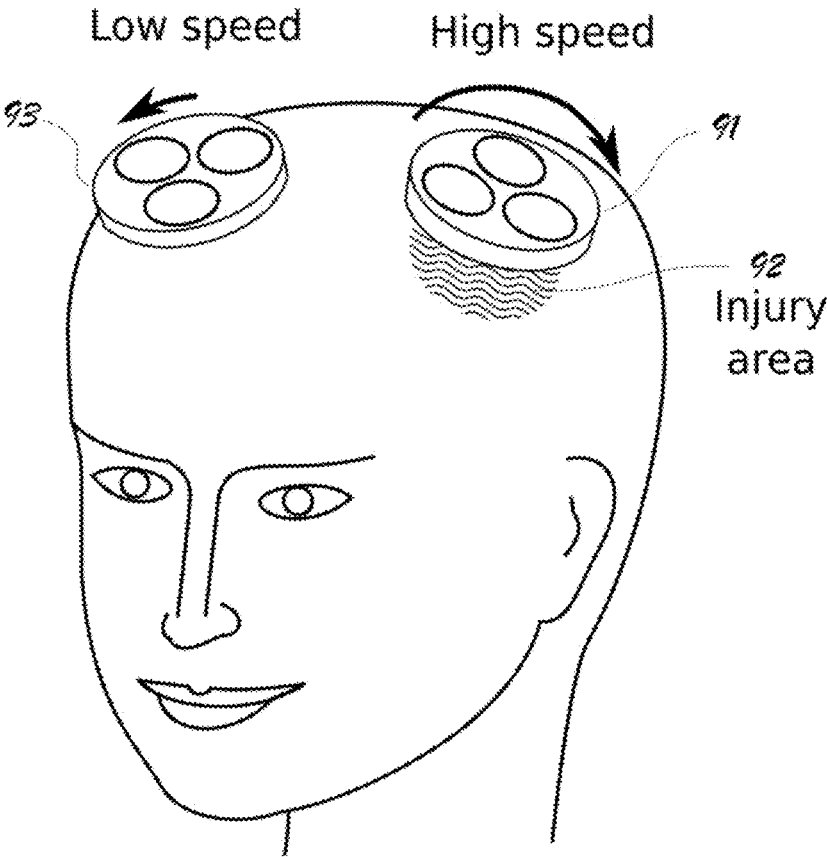

FIG. 11

## TIME-VARYING MAGNETIC FIELD THERAPY USING MULTISTABLE LATCHING MECHANISMS

### CROSS-REFERENCE TO RELATED APPLICATIONS

**[0001]** This application claims priority to and the benefit of co-pending U.S. provisional patent application Ser. No. 62/396,915, filed Sep. 20, 2016, which application is incorporated herein by reference in its entirety.

### FIELD OF THE INVENTION

**[0002]** The invention relates to methods and apparatuses for the rehabilitation and treatment of brain injury patients. More specifically, the invention relates to wearable devices that provide transcranial magnetic stimulation, preferably centered about an injured area. The device of the invention may be used throughout a rehabilitation session or during a daily routine.

### BACKGROUND OF THE INVENTION

**[0003]** Traumatic brain injuries and acquired brain injuries affect millions of people each year in the United States and beyond. These injuries leave devastating symptoms, some of which could be recovered through medications and/or rehabilitation treatments.

**[0004]** Transcranial magnetic stimulation (TMS) is a non-invasive therapy used to stimulate local regions of the brain. It utilizes electrical currents generated in coils in order to induce magnetic fields of varying frequencies. These magnetic pulses with a strength on the order of one Tesla are then focused through specific placement on the head in order to polarize target areas of the brain. In recent years, TMS has been used to treat depression (Levkovitz, Y., et al. *Brain Stimul.*, vol. 2(4), pp. 188-200, 2009) and several neurodegenerative disease including Parkinson's and Alzheimer's (Anderkova, L., and I. Rektorova *J. Neurol Sci.*, vol. 339 (1-2), pp. 15-25, 2014), with varying degrees of success. TMS has also been studied in patients with upper limb weakness following stroke with results that suggest possible benefits (Corti, M., et al. *Am. J. Phys. Med. Rehabil.*, vol. 91(3), pp. 254-270, 2012). The effectiveness of TMS for brain injury rehabilitation has been demonstrated in several recent studies (Sack, A. T., et al. *J. Cogn. Neurosci.*, vol. 21(2), pp. 207-221, 2009; Levkovitz, Y., et al. *Clin. Neurophysiol.*, vol. 118(12), pp. 2730-2744, 2007). Stimulating nerve cells in affected area via TMS may also aid in the rehabilitation of various stroke side effects other than just limb weakness.

**[0005]** After a stroke, many of the patient's cognitive and motor abilities are affected. Memory and motor control in specific areas may be impaired or lost. Current TMS for stroke rehabilitation is performed solely in a hospital setting, with each session lasting about 40 minutes. This procedure is costly, limiting availability to many patients who are mobility-impaired to start with. The present invention, in an effort to find an alternative, provides a lightweight headwear for transcranial magnetic therapy over a prolonged period of application time and one that is suitable for outpatient, e.g., at-home, use.

### SUMMARY OF THE INVENTION

**[0006]** This invention is concerned with methods and apparatuses for producing time-varying, therapeutic magnetic fields with permanent magnets. In an embodiment, a plurality of permanent magnets are embedded in a mount that can be mechanically shifted or rotated. The mount for the permanent magnets is moved to specific stable positions by energizing electromagnets to interact with the permanent magnets momentarily. Once the mount is latched to a specific stable position, no energy is required to energize the electromagnets. The juxtaposition of the permanent magnets produces various patterns of magnetic fields that change over time. The resulting apparatus is used as a lightweight wearable device for enhancing the rehabilitation of patients with acquired brain injuries.

**[0007]** In one feature according to the invention, small electromagnets are used to control the positions of permanent magnets thereby providing time-varying magnetic fields for brain injury rehabilitation. In preferred embodiments, the multiple juxtapositioned patterns of magnets are stable, meaning the electromagnets are energized only during the transition in order to change and latch the pattern from one to another. The resulting wearable device is lightweight, low-noise, and low power consumption, which can provide long-duration therapeutic sessions on a daily basis.

**[0008]** In one aspect, the invention provides a wearable apparatus for providing magnetic therapy, said apparatus comprising at least two permanent magnets situated on a mount, and at least one electromagnet situated proximate to said permanent magnets, said electromagnet being electrically connected to a power source through a switch that is in turn controlled by a controller, said controller being programmed to operate said switch to flip polarity of said electromagnet in a pattern such that said electromagnet is able to actuate continued motion in said permanent magnets without using a motor, thereby providing time-varying magnetic field for therapeutic use. In an embodiment, said mount is housed in a housing that is in turn attached to a helmet or headband for wearing on the head. In one feature, the apparatus of the invention further includes a ball bearing attached to said mount for facilitating its association with said housing. In one feature, the apparatus of the invention is configured to contain at least two stable positions for said permanent magnets such that energy required for moving said permanent magnets is reduced.

**[0009]** In another aspect, the invention provides a headwear for mounting on or around a human patient's head, comprising a housing that houses at least two permanent magnets, and a portable power source electrically connected to at least one electromagnet via a cross switch, said permanent magnets configured to move between at least two pre-configured stable positions as a result of magnetic interaction with said at least one electromagnet, wherein a controller pulses said at least one electromagnet with appropriate timing to switch the polarity of said at least one electromagnet that actuate a continued motion in said at least two permanent magnets.

**[0010]** In another aspect, the invention provides a method for generating time-varying therapeutic magnetic fields with permanent magnets by aiming its strong fields towards the treatment area and using secondary electromagnets to interact with weak peripheral fields of said permanent magnets for creating mechanical movements in said permanent mag-

nets. The method may further include the step of switching the polarity of said secondary electromagnets so that their effect on the weak peripheral fields of said permanent magnets results in said mechanical movements.

[0011] In another aspect, the invention provides a method of differential stimulations of the brain by using two sets of permanent magnets moving at different velocities with one set positioned over an injured area of the brain and the other set positioned over an other area of the brain. In one feature, the other area of the brain is uninjured.

[0012] The foregoing and other objects, aspects, features, and advantages of the invention will become more apparent from the following description and from the claims.

#### BRIEF DESCRIPTION OF THE DRAWINGS

[0013] The objects and features of the invention can be better understood with reference to the drawings described below, and the claims. The drawings are not necessarily to scale, emphasis instead generally being placed upon illustrating the principles of the invention. In the drawings, like numerals are used to indicate like parts throughout the various views.

[0014] FIG. 1. Panel A is an illustrative diagrammatic view of a disc magnet with its strong magnetic field directed toward a therapeutic target and its fringe weak magnetic field attracted to a small electromagnet on the right. Panel B shows that the disc magnet is being pushed away as the polarity of the electromagnet is switched.

[0015] FIG. 2. Panel A illustrates a sliding mechanism containing two disc magnets with an in-between coil serving as an actuator. Panel B shows that the magnets are shifted to another stable position by changing the direction of the current flow in the coil.

[0016] FIG. 3 illustrates a rotating mechanism containing three disc magnets.

[0017] FIG. 4 illustrates a pair of sliding mechanisms positioned on the head of a patient for therapeutic purposes.

[0018] FIG. 5. Panels A-D illustrate the four different stable positions of the magnets for two sliding mechanisms each containing two disc magnets.

[0019] FIG. 6 illustrates a pair of rotating mechanisms positioned on the head of a patient for therapeutic purposes.

[0020] FIG. 7. Panels A-I illustrate the nine different stable position patterns of the magnets for two rotating mechanisms each containing three disc magnets.

[0021] FIG. 8A illustrates a headwear embodiment of the invention using a rotating mechanism with two permanent disc magnets; FIG. 8B provides a closer perspective view of part of the mechanism.

[0022] FIG. 9 illustrates a preferred embodiment also using a rotating mechanism for achieving fast and quiet rotation of the magnets through the use of a ball bearing.

[0023] FIG. 10 provides an exploded view of the embodiment of FIG. 9.

[0024] FIG. 11 illustrates an application of differential stimulations by using a faster rotating mechanism over an injured area and a slower rotating mechanism on a different area in the patient.

#### DESCRIPTION OF THE INVENTION

[0025] The present invention is concerned with methods and apparatuses using juxtapositioned permanent magnets for rehabilitation treatments of acquired brain injuries such

as stroke. The apparatuses, called MagnetPeutics in some embodiments, are battery-powered headwear without being tethered to an electric outlet or a control unit such that it can be worn comfortably for hours. The invention has been made possible by the recent advancement in neodymium permanent magnets, which can produce magnetic field strengths on the order of 1 Tesla. Lithium-ion batteries have also been significantly advanced recently. However, an electromagnet driven by a battery and of a wearable weight is on the order of 1 m Tesla, which is far too weak for purpose of rehabilitation of brain injuries.

[0026] In addition to the magnetic field strength, another factor needed for effective stimulation of neurons in the brain is the speed at changing the magnetic field. The transcranial magnetic stimulation (TMS) uses strong electromagnets that can change their fields very fast. However, TMS uses a technology similar to that of the magnetic resonance imaging (MM), which requires the patients tethered to the machine and cannot be made wearable. The permanent magnet has a fixed magnetic field; the only way to make it time-varying is to change the position of the magnet mechanically. Table 1 below summarizes the differences between TMS and apparatus embodiments of the invention, MagnetPeutics.

TABLE 1

	Strength	Frequency	Session Time	Duration
TMS	1 Tesla	10 Hz	1 hr/wk	weeks
MagnetPeutics	$\frac{1}{3}$ Tesla	1 Hz	8 hrs daily	months

[0027] This invention provides at least the following solutions to overcome three technical difficulties that would have prevented the development of an effective headwear for magnetic stimulation:

[0028] 1) Multistable latching mechanism: The multistable latching mechanism is a design that allows a magnet assembly to have two or more stable positions. The transition from one position to another is done by momentarily energizing a small electromagnet. A stable position is "latched" in the sense that no energy is required to maintain in that position.

[0029] 2) Dual uses of the magnetic field: The strong magnetic field generated by the permanent magnet is directed toward the therapeutic target such as a brain injury. The weaker magnetic field on the peripheral region of the same magnet is used to interact with an electromagnet for actuating spacial change. Thus, the magnet field required from the electromagnet to actuate the desired spacial change is much weaker and does not require a strong current to produce.

[0030] 3) Motorless design: Mechanical movements are achieved by using small electromagnets to interact with the fringe magnetic fields of the permanent magnets without using an off-the-shelf motor or actuator. Thus, this design is different from the conventional approaches that employ motors. Motors are in general heavy, bulky, noisy, expensive, and high on power consumption.

[0031] FIG. 1 demonstrates the two different uses of the magnetic field of a permanent magnet. Panel A shows a permanent, disc magnet 11 with its weak fringe magnetic field attracted to a small electromagnet 12. The strong magnetic field coming off the flat surfaces of the magnet 11

is directed toward a therapeutic target **13**. The polarity of the electromagnet **12** is set to lead to a movement **14** where the electromagnet **12** attracts the disc magnet **14**. Panel B shows that the polarity of the electromagnet **15** is switched, resulting in a movement **16** where the disc magnet is pushed away.

**[0032]** Referring now to FIG. 2, in an exemplary embodiment according to the invention, a bistable sliding mechanism is provided. Specifically, a mount **21** that carries two permanent disc magnets **22** can slide freely in a mount **23**. The mount can be shifted back and forth between two stable positions, e.g., along a linear or curved track. A small coil (electromagnet) **24** is positioned between the two permanent disc magnets. To shift the mount, the coil is energized momentarily by a battery **25** via a cross switch **26**. When the cross switch changes the direction of the current flowing through the coil, so does the polarity of the electromagnet **24**. Once the mount **23** is moved to the desired position, no energy is further required for the electromagnet to hold the mount at that position. By changing the polarity of the electromagnet, the mount can be latched to one of the two stable positions. Panel B shows that the cross switch **27** is set to the alternative position. As a result, the change in the polarity of the electromagnet causes the disc magnets and its mount to slide to the other stable position on the right side.

**[0033]** Referring now to FIG. 3, in another exemplary embodiment according to the invention, a tristable rotating mechanism is provided. This embodiment employs a rotating mechanism. Three permanent disc magnets **32** are embedded in a rotatable circular mount **31**, enclosed in a stationary housing **33**. The mount can be moved to one of three stable positions through the use of three electromagnets **34** that interact with the magnetic fields of the permanent disc magnets. Each of the electromagnets is energized by a controller **35** with appropriate timing.

**[0034]** FIG. 4 shows an application of the invention for providing transcranial magnetic stimulation over an area of an acquired brain injury such as stroke. Two sliding units **41** are used to provide a juxtaposition of four permanent disc magnets. The two disks within the said units are shifted at various frequencies to allow for the spacial changes as well as the temporal changes of the magnetic field. As shown in FIG. 5 (panels A-D), with two sliding units **51**, a total of four juxtaposition patterns with different latching positions for the permanent magnets can be achieved.

**[0035]** FIG. 6 shows a pair of the rotating units **61** positioned on the head of a patient for therapeutic purposes. Each of the rotating mechanisms has 3 stable positions. A time-varying magnetic field is created by rotating each of the two magnet assemblies among the three stable positions. As shown in FIG. 7 (panels A-I), with two rotating units a total of nine juxtaposition patterns, with different latching positions for the permanent magnets, can be achieved. Switching through these multistable latching positions allows for the delivering of complex stimulation patterns both in space and in time.

**[0036]** Referring now to FIGS. 8A and 8B, in an embodiment of the invention, a rotational mechanism was employed to achieve a faster and continuous circular motion of the permanent magnets. As shown in FIG. 8A, a magnetic therapeutic probe was positioned on the head with the support of a lightweight helmet. The placement of the therapeutic probe in the helmet was preferably flexible

enough to target a specific injury area of the brain, such as the frontal lobe, the temporal lobe, parietal lobe, and occipital lobe.

**[0037]** As shown, two permanent magnet discs **75** were inserted into two openings in a holder **79**. The holder **79** was in turn fitted to a circular housing **76** that supports rotational motion. A microprocessor was used for controlling the timing and the therapeutic protocol. The magnets were rotated through the use of a DC motor **77**. A pulse width modulator was used to control the speed of the motor.

**[0038]** In an example representing the embodiment shown in FIGS. 8A and 8B, the mounting holder and housing were 3D-printed in ABS plastic by using a MakerBot Replicator 2x (Brooklyn, N.Y.). The permanent magnets used were N52 neodymium discs of 1 inch diameter and ¼ inch in thickness. The magnetic flux density normal to the surface was 0.33 T at the center of the disc, and 0.52 T on the perimeter. The holder was continuously rotated by using a 12V DC motor (Model JSX330-370, Dmiatech) with a rated torque of 4 Kg-cm, a gear-down ratio of 330:1, and a maximum no-load speed of 24 rpm.

**[0039]** The control unit was developed around a PIC18F4525 microprocessor by using an ICD3 in-circuit programmer and the MPLab Integrated Development Environment (Microchip, Chandler, Ariz.). The electronics were initially developed on a breadboard and can be converted to a printed circuit board. The electronics and the DC motor were powered by use of two 9V batteries to achieve a maximum voltage of 18V.

**[0040]** Referring now to FIGS. 9 and 10, in yet another exemplary embodiment according to the invention, a rotating mechanism preferably with multiple stable latching positions (e.g., four in the illustrated embodiment) is provided. This embodiment is intended for achieving fast and quiet rotation of the permanent magnets with the help of a ball bearing **84**. Multiple (e.g., four) cylindrical-shaped magnets **81** are enclosed in, preferably attached to, a rotatable mount **82**. Better viewed in FIG. 10, the mount **82** is fitted into a stationary housing **83** via a ball bearing **84** as follows: the mount **82** has an opening or crater **90** on its top that fictionally engages or is otherwise bonded or affixed to the outer ring of the ball bearing **84**. The inner ring of the same ball bearing **84**, is in turn fitted over (fictionally engages or otherwise affixed to) a protruding hub **89** that is part of the stationary housing **83**. As a result, as shown in FIG. 9, the ball bearing **84** facilitates the hosting/shielding of a spinning mount **82** inside a stationary housing **83**.

**[0041]** The stationary housing **83** is in turn mounted over a headwear (e.g., a helmet or headband) for a patient to wear around the head. A preferred material for the ball bearing **84** is ceramic in order to eliminate dragging force that would have resulted from the magnets had the bearing been magnetizable metal. For instance, commercially available ball bearings such as the ones used in skateboard, inline skates and the Fidget Spinners can be used in this embodiment.

**[0042]** Four electromagnets (metal coils **85**) are positioned around the housing **83** to turn the magnet mount **82**. The coils are driven by a power source, here a battery **86** (e.g., lithium-ion batteries) via an electric cross switch **87**. The cross switch, e.g., an H bridge, is operated by a controller **88** that can program when and how frequently the cross switches are flipped. When the controller first turns on the electromagnetic coils **85**, they generate magnet fields strong enough to interact with the weak fringe magnetic fields

around those permanent magnets **81** such that the permanent magnets **81** are put in motion. As the permanent magnets **81** move, however, their fringe magnetic fields move with them—a south pole from a first permanent magnet that originally attracted it to a particular coil's north pole now gives way to a north pole from a second permanent magnet. The controller **88** is programed to flip/switch the cross switch **87** at that moment so that the direction of the current through the four coils **85** switches, reversing the polarities of these electromagnetic coils, thereby continue to move the permanent magnets **81** in the same rotational direction (see FIG. **9**). This results in the rotation of the four permanent magnets **81**, bringing the mount **82** spinning about itself from one stable position to the next, utilizing minimal amount of energy.

[0043] By pulsing the cross switch **87** with appropriate timing, the magnet mount **82** spins continuously. One of the novelties of this design is that it achieves a spin motion of the magnet mount **82** without using a motor, but relies solely on the changing magnetic fields surrounding the permanent magnets. The use of a motor would have several disadvantages for a headwear device including weight, size, cost, noise, and power consumption. Besides being programed or otherwise configured to operate the cross switch **87** in a pattern such that the electromagnetic coils **85** are able to effectuate continued motion in the permanent magnets, the controller **88** is also capable of adjusting the spinning speed of the magnet mount **82** as well. This provides a way to fine-tune the frequency of the time-varying magnetic fields given off by the permanent magnets in order to achieve various therapeutic results. In a preferred embodiment of the invention, the frequency of the therapeutic magnetic field reached about 3.0 Hz and above. A “continued” motion, as used herein, does not have to be continuous and can include pauses. In one embodiment, a continued motion includes returning to a starting position at least once, preferably multiple times. In a preferred embodiment, the continued motion is continuous. Note embodiments of the invention, as in this one, are not always required to engineer stable positions for the moving permanent magnets.

[0044] Referring now to FIG. **11**, in an embodiment of the invention, a device can be constructed such that the permanent magnet units can be controlled to rotate at different speeds to create either excitatory or inhibitory effects. Such effects can be alternated depending on how the device is controlled or programed. For example, unit **91** rotating at a higher speed is positioned over an injury area **92** of the frontal lobe of the left brain. Another unit **93** rotating at a lower speed is positioned over a normal area of the frontal lobe of the right brain. This arrangement illustrates a platform that differential stimulations could create the potential inhibitory/excitatory effects during the process of brain rehabilitation. Further, parameters can be optimized including the juxtaposition patterns, frequency of changes, combination and synchronization of targeted treatment areas (left/right, frontal/temporal/parietal/occipital).

[0045] While the present invention has been particularly shown and described with reference to the structure and methods disclosed herein and as illustrated in the drawings, it is not confined to the details set forth and this invention is intended to cover any modifications and changes as may come within the scope and spirit of the following claims. All publications and patent literature described herein are incor-

porated by reference in entirety to the extent permitted by applicable laws and regulations.

What is claimed is:

1. A wearable apparatus for providing magnetic therapy, said apparatus comprising:
  - at least two permanent magnets situated on a mount, and
  - at least one electromagnet situated proximate to said permanent magnets, said electromagnet being electrically connected to a power source through a switch that is in turn controlled by a controller, said controller being programed to operate said switch to flip polarity of said electromagnet in a pattern such that said electromagnet is able to actuate continued motion in said permanent magnets without using a motor, thereby providing time-varying magnetic field for therapeutic use.
2. The wearable apparatus of claim 1, wherein said mount is housed in a housing that is in turn attached to a helmet or headband for wearing on the head.
3. The wearable apparatus of claim 2, further comprising a ball bearing attached to said mount for facilitating its association with said housing.
4. The wearable apparatus of claim 1, wherein said permanent magnets are configured to rotate, bringing said mount to spin about itself
5. The wearable apparatus of claim 1, wherein said permanent magnets are configured to slide along a linear or curved track.
6. The wearable apparatus of claim 1, wherein said continued motion in said permanent magnets is continuous.
7. The wearable apparatus of claim 1, wherein said apparatus is configured to contain at least two stable positions for said permanent magnets such that energy required for moving said permanent magnets is reduced.
8. The wearable apparatus of claim 1, comprising at least three permanent magnets.
9. The wearable apparatus of claim 1, wherein said permanent magnets are rare-earth magnets.
10. The wearable apparatus of claim 1, wherein said power source comprises a battery.
11. The wearable apparatus of claim 1, wherein said switch is a cross switch.
12. A headwear for mounting on or around a human patient's head, comprising a housing that houses at least two permanent magnets, and a portable power source electrically connected to at least one electromagnet via a cross switch, said permanent magnets configured to move between at least two pre-configured stable positions as a result of magnetic interaction with said at least one electromagnet, wherein a controller pulses said at least one electromagnet with appropriate timing to switch the polarity of said at least one electromagnet that actuate a continued motion in said at least two permanent magnets.
13. The headwear of claim 12, wherein said at least two permanent magnets are rare-earth magnets.
14. The headwear of claim 12, wherein the housing contains at least four permanent magnets rotating continuously.
15. The headwear of claim 12, wherein said at least two permanent magnets rotate among at least three pre-configured stable positions.
16. A method for generating time-varying therapeutic magnetic fields with permanent magnets by aiming the strong fields towards the treatment area and using secondary



electromagnets to interact with the weak peripheral fields of said permanent magnets for creating mechanical movements in said permanent magnets.

17. The method of claim 16, further comprising switching the polarity of said secondary electromagnets so that their effect on the weak peripheral fields of said permanent magnets results in said mechanical movements.

\* \* \* \* \*