

# TEAPC: Adaptive Computing and Underclocking in a Real PC

Augustus K. Uht and Richard J. Vaccaro  
University of Rhode Island  
Microarchitecture Research Institute  
Department of Electrical and Computer Engineering  
4 East Alumni Ave.  
Kingston, RI 02864, USA  
{[uht@ele.uri.edu](mailto:uht@ele.uri.edu), [vaccaro@ele.uri.edu](mailto:vaccaro@ele.uri.edu)}

## Abstract

TEAPC is an IBM/Intel-standard PC realization of the TEAtime performance “maximizing” adaptive computing algorithm, giving performance beyond worst-case-specifications. TEAPC goes beyond the TEAtime algorithm by adapting to the current CPU load. It is also the first machine to use extensive underclocking for disaster tolerance, low power consumption and high reliability. This is all done dynamically, at runtime, on an unmodified standard operating system (Windows 2000) with a purely software-implemented feedback-control based algorithm.

## 1 Introduction

*Adaptive* systems “maximize” performance or “minimize” power consumption with respect to changes in environmental, operating and manufacturing conditions. *Underclocking* reduces the operating frequency below that normally specified, reducing power consumption and increasing reliability. In this paper we present a prototype based on the standard IBM/Intel PC architecture realizing both adaptive computing and underclocking.

In prior work we demonstrated an adaptive system called *TEAtime* with a simple physical prototype (see Section 2). We wanted to fully demonstrate TEAtime’s potential by putting it in a production microprocessor, but that is problematic. We therefore did the next best thing: demonstrating TEAtime’s adaptive attributes on a real PC assembled with COTS (Commercial Off-The-Shelf) parts. *TEAPC*, the resulting prototype, goes further than TEAtime: It adapts to current CPU computational loading, and greatly underclocks for disaster tolerance and low power, while still functioning normally.

The initial TEAPC implementation used timing-based sensors, similar to that used in the TEAtime prototype. For reasons to be discussed later, this was abandoned in favor of basing the real-time performance or frequency of the CPU on the CPU’s

real-time internal temperature. Since this is the major component of variation of timing within an Intel microprocessor (the CPU’s core voltage is highly regulated and approximately constant), it mirrors the original TEAtime philosophy. Further, it is possible to base the real-time performance on the real-time power consumption of the entire PC; the latter is partially addressed in this paper.

We have implemented the entire control system in software, in a Windows application. It runs in a normal application mode on Windows 2000, multitasking normally with other applications. CPU frequency and core voltage are changed dynamically, based on the output of a feedback control system using the CPU chip temperature as its primary input. While details such as specific hardware device addresses may change, the basic approach and detailed realization of the control loop and underclocking should be implementable on any PC to be built, as well as many that already exist.

Summarizing, our goals are: TEAPC should have the adaptation and frequency maximization properties of TEAtime; additionally, TEAPC should realize adaptation to varying CPU loads, low power consumption on-demand, and disaster tolerance. All of these goals have been realized with the aid of a purely software-based feedback control system, employing CPU frequency underclocking as needed.

The rest of the paper is organized as follows. Section 2 discusses prior work and background information. Section 3 describes the initial TEAPC solution and real system constraints. In Section 4 TEAPC’s final version is discussed, along with the experimental methodology. Section 5 presents the experiments, data, and analyses. Examples of different TEAPC operating scenarios are given in Section 6. We conclude in Section 7.

## 2 Prior Work

Performance- and power- adaptive computing approaches have only been proposed in the last

decade or so. Most techniques are mainly concerned with power reduction [1, 4, 5], while a few recent methods consider performance enhancement [6, 8]. Most methods use voltage-scaling for power-reduction. The recent Razor proposal [2] and the earlier TIMERRTOL model [11] are unusual in that timing errors are not avoided, but rather are used as a feedback mechanism to regulate either power consumption (Razor) or performance (TIMERRTOL). They employ different methods to recover from the timing errors. One of the key observations that can be made about all of this adaptive computing work is that in general the same basic mechanism can be used for either power consumption or performance enhancement (or both). These methods achieve better-than-worst-case performance. In the case of Razor, its operating voltage is lowered below specs, reducing power.

Skadron *et al* [9] first considered the use of formal feedback control theory as applied to the on-chip control of chip temperature of a microprocessor. Instruction fetch toggling was used to control the chip temperature. In [10] on-chip frequency-scaling was used to regulate the chip temperature using a simple linear relationship between frequency and temperature; formal control theory was not needed since the relevant thermal delays and changes in frequency and temperature were small. Slowdown was also small. Reliability could not be enhanced. In TEAPC, performance can be increased with the particular methods used, and at the system level, without chip modification. Should reliability be an issue, TEAPC can instead enhance that.

Rohou and Smith [7] used operating-system based software to control temperature of a chip in a system via frequency scaling; performance only decreases, never increases. The frequency control mechanism puts the CPU in either a doze state or a full operation state, while TEAPC utilizes sophisticated feedback control for adjustment of frequency, temperature and reliability. TEAPC executes all code normally, all of the time. Also, TEAPC does not require operating system modifications, and can increase performance.

Our recent work, TEAtime (Timing Error Avoidance) [12-14], approximated a maximization of performance much above that normally allowed by standard design practices. The key component was *tracking logic*, a one-bit wide copy of the worst-case-delay path between any pair of flip-flops in the digital system, plus a small delay margin. In operation, the tracking logic is fed a never-ending stream of alternating one's and zero's. The operating frequency of the system is incrementally increased until an error occurs in the output of the tracking logic; at this point

the frequency is decreased until the error ceases, and then the process repeats. Since the tracking logic is guaranteed by design to be slower than any other path in the system, any timing error will occur in the tracking logic first, and only there. Hence, timing errors in the main system are completely avoided. This also completely avoids added pipeline stalls or other additional clock cycles. Throughput increases of almost a factor of two were demonstrated in a physical TEAtime prototype.

TEAtime adapted to changes in the environment (e.g., temperature), operating conditions (e.g., supply voltage) and manufacturing conditions (e.g., quality of a given production run), dynamically "maximizing" performance

While the TEAtime prototype demonstrated the basic worth and functionality of the TEAtime idea, it used a very simple home-brew processor implemented on an FPGA. In our desire to extend the TEAtime ideas and applications, we decided to implement and evaluate TEAtime on a real PC, using COTS parts. We have created a high-performance feedback-control system using normal application software, not requiring any operating system modifications. Disaster tolerance is achieved, and reduced power consumption and increased reliability may be user-specified. TEAPC is the result.

## 3 Initial TEAPC Architecture and Control System

### 3.1 Foundations of TEAPC

The guiding principle in the design of TEAPC was to use as much COTS hardware and software as possible. To this end, TEAPC's foundation is a standard IBM/Intel PC architecture assembled out of COTS parts. (A commercial PC was not considered, since it would be unlikely to allow the kind of internal access we required. However, the results of this work can easily be applied to commercial PC's, during their design, construction and/or testing.)

We wished to be conservative in our results, and knew that it is always hardest to speedup or otherwise control more advanced components. We therefore assembled TEAPC out of what were at the time high-end parts: a 3.0 Ghz Intel Pentium 4 microprocessor with an 800 MHz bus and an Intel 875P chipset (a "chipset" is the glue logic that connects the CPU to the main memory and I/O devices; in Figure 4 it is the Northbridge/Southbridge pair of chips). The main memory used high speed DDR (Dual Data Rate) dynamic RAM.

## 3.2 Initial Approach Towards a TEAPC Prototype

Our initial plan and activities were to closely model TEAPC operation on that of the TEAtime prototype. While we were of course unable to embed tracking logic in the existing components, especially the CPU, we were still able to create tracking sensors whose delay varied with temperature, supply voltage, etc. While we did not fully validate the following, since each sensor was a standard CMOS logic gate integrated circuit we felt the sensor would to a large degree mirror the sensitivity of the internal logic of the parts to be monitored.

We monitored four components on the PC's motherboard: the CPU, the Northbridge and the two main memory modules. The sensors were 4-gate surface-mount IC's with 50 mil (thousandths of an inch) pitch leads. Each sensor was thermally-coupled to its component by fixing the top (non-lead) side of the sensor to the component with thermal grease or tape between the two. In reality, to avoid complex machining, each sensor was attached to the heat sink of its component, as close as possible to the component itself.

Each sensor's gates were wired in series at the sensor, with an input, an output and power connections brought out on four 30 gauge wires to an added FPGA. The FPGA contained counters and other control circuitry to measure the delay through each sensor. The FPGA in turn connected to TEAPC itself through the parallel port. The `teapc` program received the digitized delays, and used them as inputs to the TEAPC control algorithm.

The control algorithm uses the CPU's frequency as the algorithm's dependent output. Every component's temperature is dependent on the component's power dissipation, and the latter is roughly proportional to the component's operating frequency. Since each of the components' clocks has roughly the same frequency as the CPU's clock, they all heat up at roughly the same time. This in turn heats the sensors, increasing their delay, and the feedback loop is complete; see Figure 1.

## 3.3 The Feedback Control System

Hope springing eternal, the first attempt at a control system was to use essentially the same one as in the original TEAtime prototype: a zero-delay feedback system incrementally increasing or decreasing the frequency (Note: from now on, 'frequency' refers to the CPU's frequency, which indirectly controls the rest of the components' frequencies.) The classical method worked poorly, often giving large frequency

oscillations (peg-to-peg) and slow response. The main reason for the inadequacy of this simplistic approach is the thermal capacitance of the components' heatsinks, with the resulting roughly exponential time delay between component heating and sensor response.

We then used formal feedback control system theory to eventually achieve a fast frequency response to thermal changes. The basic control input is a temperature setting,  $T_{set}$ , used by the control system to maintain a CPU temperature of  $T_{set}$  degrees C.  $T_{set}$  would typically be made equal to a temperature just above the maximum CPU frequency under full load, so as to maximize performance. However, should the user desire to save power or increase the reliability of the CPU  $T_{set}$  can be reduced.

The original system had four feedback loops (see Figure 1), one per sensed component, and only one dependent control variable, the frequency. The system still oscillated greatly. This is because the system is formally uncontrollable: Its controllability matrix is not full rank. Physically, the feedback loops cannot be independently controlled since they have the same input. Since the only component near to overheating was the CPU, the other three sensors were removed from the control system. We verified the safety of the other components only after monitoring the temperature of each of them under many conditions, using a thermocouple placed next to each sensor.

The control system went through several single-pole design iterations, an example of which is shown in Figure 2. While the frequency oscillations were reduced, the system still responded slowly.

Our current solution to the control system design problem completely eliminated the external sensor system, instead relying on the internal temperature of the CPU for the only input to the system. This sped up the system considerably. Second, the final system was designed with state-of-the-art discrete-time techniques as an integral control system using state-space methods [3, 15]. The system was modeled from measured input/output data using the System Identification Toolbox (from the Mathworks). The Toolbox returned a second-order model, and this was approximated with a first-order system model. The latter is shown in Figure 3. This system has excellent response characteristics, having a frequency settling time of only about 10 seconds for a  $T_{set}$  change equivalent to a change in frequency from 2.5 GHz to 3.5 GHz of the CPU under full load.

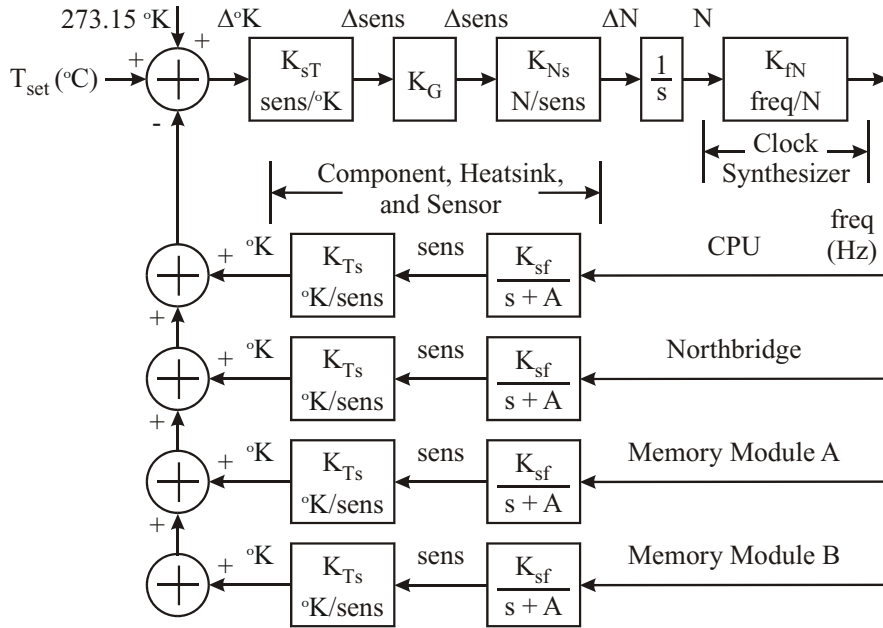

Note: all of the constants of the four components differ.

**Figure 1. First formal feedback control system tried. Each of four sensors has its own feedback path.**

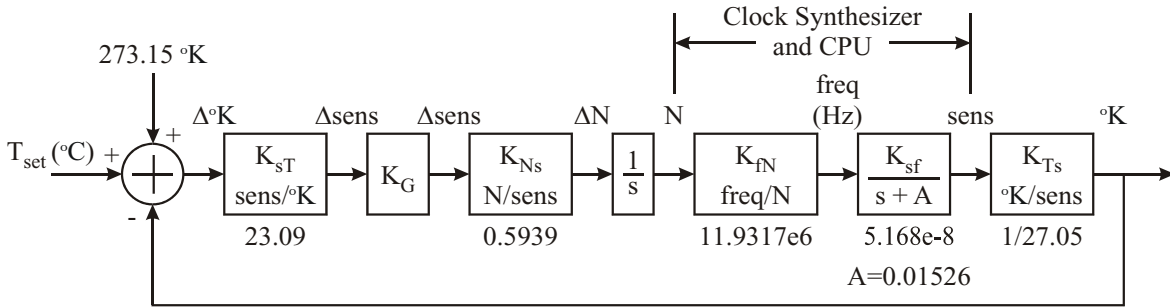

**Figure 2. Single sensor, single feedback path control system.**

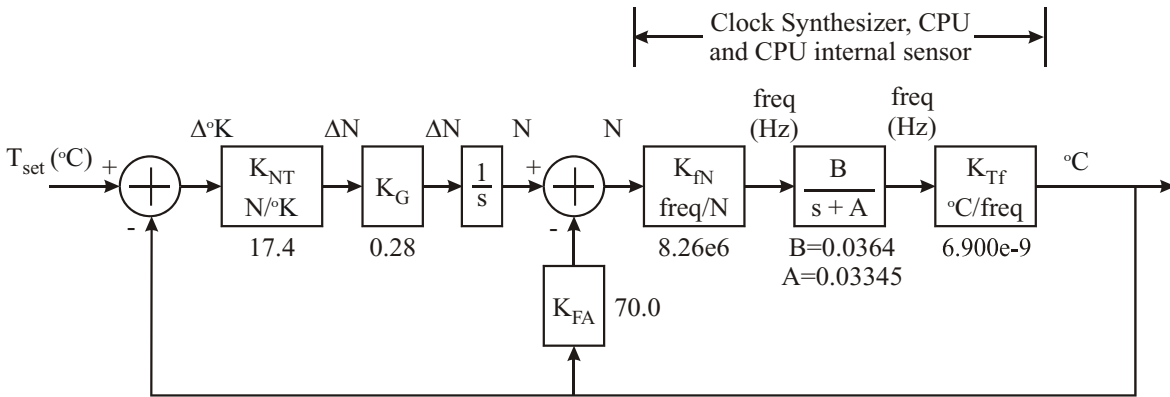

**Figure 3. Final TEAPC feedback control system.**

## 4 Final Version of TEAPC and Experimental Setup

The final version of TEAPC is shown in Figure 4, with its major relevant components listed in Table 1. Figure 5 is a photograph of TEAPC.

### 4.1 Final TEAPC System

With the external sensors and associated extra control hardware eliminated from the system, the new parts of the TEAPC solution are only software, utilizing hardware information and control paths already existing on the motherboard. Referring to Figure 4, the `teapc` program reads the CPU's core temperature, core voltage, and fan speed from the Super I/O chip. The program reads and sets the CPU frequency by accessing the Clock Synthesizer. Likewise, the program reads and sets the CPU core voltage via the Vcore Regulator Controller. The Synthesizer and Regulator are accessed with the two-wire SMBUS through the Southbridge. Program access to all of these components, as well as the control registers of the chipset itself, is made via the x86 I/O address space. Readily-available freeware off of the Web is used to directly access the I/O space from within the (Windows) program. Presumably, a commercial version of the software would use safer indirect access within the Windows API (Application Program Interface).

### 4.2 Software Realization of Modified TEAtime Algorithm.

The TEAPC control program was written in C and C++. The program is only 800 Kbytes large, including the feedback control system. The program uses 5% or less of the CPU's computational capacity.

The control loop is updated every second. This is straightforward. The non-CPU parts of the control loop are represented in the program by a list of the blocks previously shown. At an update point, the program starts with the input data (the running-averaged CPU temperature), and re-calculates the control block values around the loop. The new CPU frequency is the main output, with the CPU core voltage sometimes linked to the frequency. For safety, the maximum and minimum possible output frequencies are hard limits; when reached, we say the frequency has "pegged" (as in an old analog meter).

### 4.3 Added Hardware for Experiments

A simple on/off switch was added for the disaster tolerance experiment. An external power meter with

a serial interface was also added to measure changes in total PC power consumption.

## 5 Experiments

The experiments characterized TEAPC's operation and demonstrated its achievement of the project's goals. Only the CPU frequency was directly varied by the feedback control system. The Northbridge and memory clock frequencies are a fixed fraction of the CPU frequency, and thus also change. In two cases the CPU core voltage was varied as a function of the CPU clock frequency. All other components in the PC used their standard operating conditions, in particular their normal frequencies and voltages.

In general, we see that although there is some oscillation in the dependent variables, it is not great. The CPU temperature may still oscillate, even with a constant CPU frequency; this is most likely due to load changes in the CPU-100%-loading burn-in program (SiSoft's Sandra).

In the experiments,  $T_{set}$  was often set to a point lower than that needed for maximum performance. This was done both to characterize the system and to demonstrate its operational flexibility; see Table 3.

### 5.1 Step Response to Frequency Change

Table 2 shows TEAPC's CPU temperature's reaction speed to changes in CPU frequency. Overall, the CPU neither heats up or cools very quickly. The settling time varies substantially with load and direction of frequency change. It is relatively easy to heat up the CPU, but takes considerably longer to cool it, regardless of the CPU's load. This is intuitive, as it is usually the case in thermodynamics that forced addition or removal of energy to a system will heat up or cool, respectively, faster than with a passive transfer mechanism. In TEAPC's case the increasing frequency directly increases the CPU's power consumption and temperature, whereas removal of the resulting heat depends on the thermal resistance and capacitance of the passive cooling system.

Interestingly, the response times approximately double from a full load condition to an approximately unloaded condition. This may arise from the internal CPU power control system, which shuts down major sections of the CPU when the sections are not used. Hence, in a lightly loaded system a given increase in frequency increases power consumption less than a fully loaded system, in which the entire chip is affected by the frequency change.

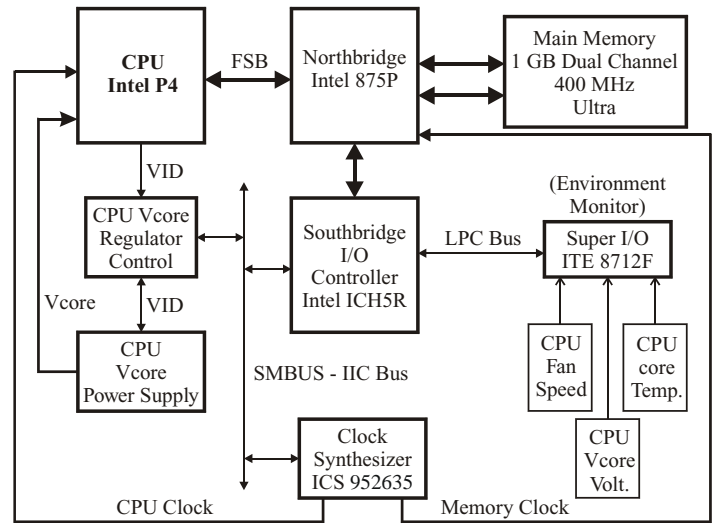

Only directly relevant components and connections are shown. (FSB - Front Side Bus) (LPC - Low Pin Count)

**Figure 4. Major motherboard structures used in TEAPC control system.**

**Table 1. Major TEAPC components and extra experimental equipment.**

PC Component	Manufacturer	Part Number/Description
Motherboard	Gigabyte	GA-8KNXP (Rev. 2); w/DPS regulator
CPU	Intel	P4 3.0 GHz, 800 MHz bus
Chipset	Intel	875P, ICH5R
Clock Synthesizer	ICS	ICS952635
Super I/O (Environment Mon.)	ITE	IT8712F V0.6
CPU Volt. Regulator Control	ITE	IT8206R V0.1
Main Memory	Ultra	U10-5903R; 2 x 512 MB; 400 MHz DDR, Dual Channel (Operated at 320 MHz.)
Operating System	Microsoft	Windows 2000 SP4, HT disabled
Disk System – RAID 0+1	ITE	GigaRAID IT8212F
Disks	Maxtor	4 x 6E040L0, 40 GB, 133MHz IDE
Equipment for experiments only		
Fan Controller & Temp. Mon.	Thermaltake	Hardcano 12; for 4 fans, 4 thermocouples
Power Meter	Electronic Educational Devices	watts up? PRO (Note: this is the unit's model name.)
CPU Fan Controller	custom	On/Off, control sel. (MOBO or Hardcano)

**Table 2. Step response of CPU temperature to CPU frequency changes, under differing loads.**

Run ID	CPU Utilization	Frequency Transition (GHz)	Start Temp. (deg. C.)	End Temp. (deg. C.)	Settling Time (2%) (sec.)
91	100%	3.5 to 2.5	59.3	53.7	90
92	100%	2.5 to 3.5	52.5	58.9	60
93	~5%	3.5 to 2.5	53.1	48.0	170
94	~5%	2.5 to 3.5	48.0	52.9	130

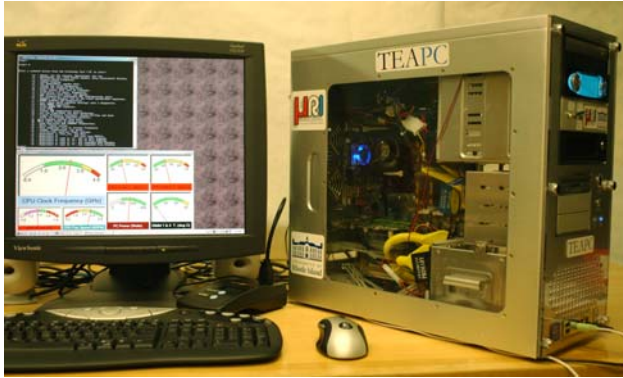

**Figure 5. TEAPC prototype, with experiment instrumentation shown on the display.**

## 5.2 Performance Maximization

Figure 6 demonstrates TEAPC's ability to operate at better-than-worst-case performances via dynamic adaptation of the clock frequency to desired changes in operating temperature. In the figure, TEAPC is under full load and starts executing in an underclocked power-saving mode, then has its Tset raised appropriately. TEAPC rapidly increases its frequency, strictly in response to the control system. It reaches full performance (the hard upper-limit 'peg') within about 10 seconds, even though it takes longer for the actual CPU temperature to reach its final value. The CPU core voltage was held constant at its high value, 1.5125 V., and was not linked to the frequency.

## 5.3 Modest Frequency Changes

Figure 7 shows the results of a small step change in frequency, midway between the two peg points. Voltage-to-frequency linking was used again. By changing Tset in the usual way, the frequency was changed from 2.75 GHz to 3.25 GHz, with the final average value reached after about 150 seconds. From the results we see that small frequency changes are also handled by the control algorithm, although pegging may still occur to a limited degree.

## 5.4 Load Adaptation

TEAPC also dynamically and automatically adapts to changes in computation load. In Figure 8 the system is initially stable at the upper peg point of 3.5 GHz, and under no load. At the indicated point, the Sandra CPU-burn program is started, putting the CPU under full load. The control system senses the rapid increase in CPU temperature, and immediately drops the frequency. Within about 50 seconds TEAPC's frequency has dropped to about 2.65 GHz, on average, while the CPU temperature has stayed relatively constant around the temperature set point.

The power consumption stays about the same. Again, the CPU core voltage was held constant at its high value, 1.5125 V., and was not linked to the frequency.

We performed the same experiment, this time with the CPU core voltage a function of frequency. The highest frequency corresponds to the highest voltage, and the lowest frequency corresponds to the lowest voltage. The results are shown in Figure 9. The lower voltage and hence reduced requirement for power allow a higher final operating frequency, about 3.0 GHz, with no change in the power consumption. Thus, the voltage-to-frequency linking results in higher performance for the same power.

## 5.5 Disaster Toleration and Low-Power Setting

The disaster tolerance experiment consists of turning off the CPU's cooling fan while the CPU is under full load and at its "maximum" frequency. Moving air from a fan through a passive heatsink greatly lowers the heatsink's thermal resistance and thus greatly increases the amount of heat a heatsink can dissipate. Hence, stopping the fan is a disastrous condition, and an excellent test of TEAPC's adaptation abilities.

To date, we have only tested the disaster tolerance manually. The CPU was first allowed to stabilize its temperature, *et al* while operating at a "maximum" frequency of 3.55 GHz, and while under full load. The CPU's core voltage was linked to the CPU frequency. Right after the fan was turned off, the frequency was set manually to its "minimum" value of 1.1 GHz; this also caused the core voltage to decrease to about 1.0875 V. from its normal 1.5125 V. The CPU temperature dropped slightly while the frequency and voltage were decreasing, then rose slightly to a steady 62 degrees C. The automated system adaptation system should be able to do as well. At the low frequency, TEAPC was still functional; no OS or other crashes occurred, the burn program still worked, and Web browsing was fully functional and executed simultaneously with the burn and a PowerPoint presentation. Sample web pages included video clips. Therefore, while the system operates at reduced performance, it is still functional at the low frequency and voltage, with the CPU fan stopped; disaster tolerance is achieved.

The power savings at the low frequency and voltage settings were substantial. The overall PC power decreased from about 222 W. down to 140 W., under full load, a power savings of 37%. Underclocking is a useful tool.

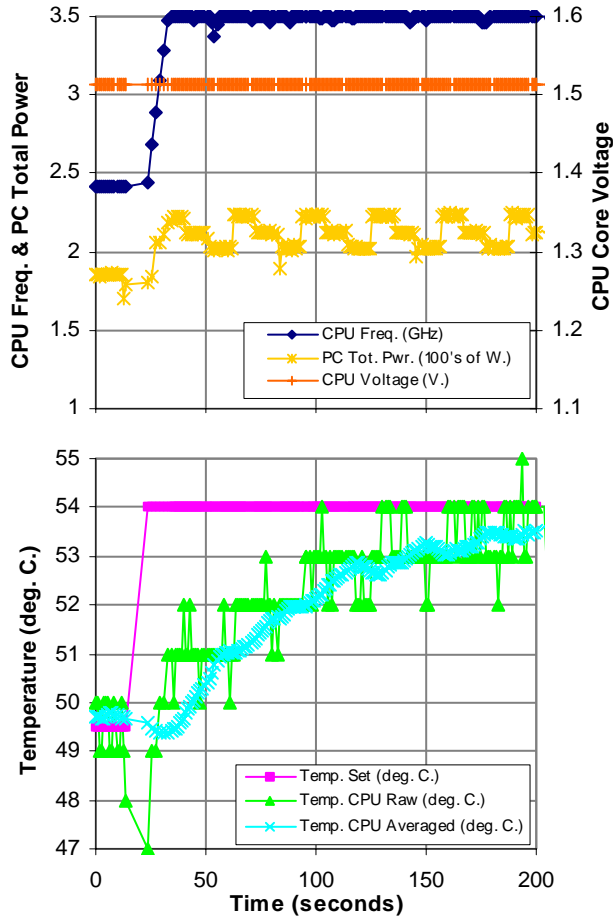

Figure 6. "Maximize" performance adaptation. Vcore not linked to CPU frequency.

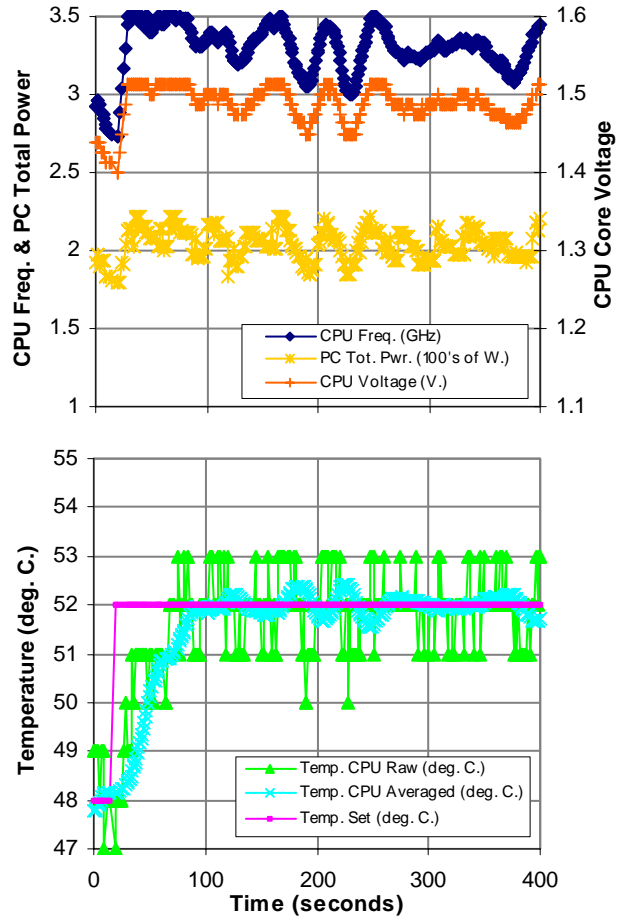

Figure 7. Small step adaptation, 2.75 GHz (Tset=48 C.) to 3.25 GHz (Tset=52 C.). Vcore is linked to CPU frequency.

### 5.6 Real Workload Effects

Except as discussed in the following section, TEAPC has little effect on the base performance of any PC workload. The `teapc` program uses little CPU time. Ignoring the demands of the experimentation instrumentation and display, both of which would be unnecessary in a production system, `teapc` uses less than 5% of the CPU when fully engaged. This is inconsequential compared to its benefits, and is inconsequential in an absolute sense when the PC is operated in the overclocking mode. In the latter case, TEAPC provides a substantive increase in CPU-bound workload performance.

If TEAPC is operated in an intermediate mode, between maximum performance and minimum power consumption, the performance dynamics are likely to be as complex as the dynamics of the workload itself, if not more complex. However, the net mean performance is not likely to change, and unstable

performance dynamics should be avoidable with a well-designed control system.

For example, first consider Figure 6; the frequency is approximately constant, and the core voltage is constant. However, the Sandra burn-in code appears to have three distinct phases of operation, each one using different parts of the CPU and hence using a different amount of power; notice the step-function shape of the power consumption. This shape repeats with each run of the burn-in code; each run of the latter routine executes for about 30 seconds. Next, consider Figure 7, with TEAPC operating in an intermediate mode, in which the frequency can vary. The power curve is no longer neat, but mirrors the complexity of both the frequency and temperature curves. However, also note that the mean performance is relatively stable.

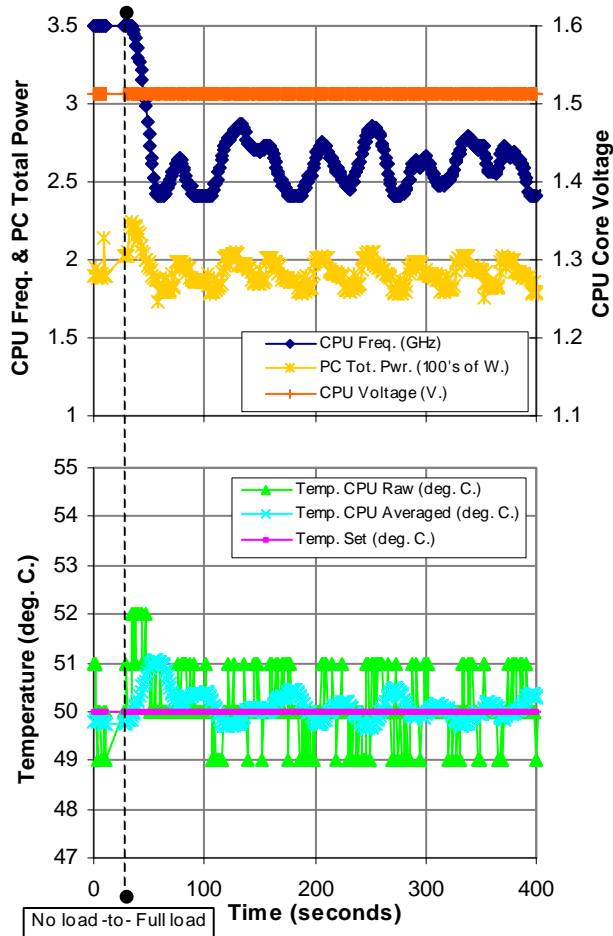

Figure 8. Load adaptation test. Vcore NOT linked to CPU frequency.

## 6 TEAPC Operation in Practice

TEAPC can be operated in many ways depending on the needs or desires of the user. The user may change the operating characteristics dynamically to suit current demands. Only Tset need be changed to accommodate different circumstances. For examples, see Table 3.

## 7 Summary

TEAPC demonstrates the numerous and deep possibilities inherent in modern PC's when advantage is taken of low-level inputs and outputs, and, most especially, when a well-designed feedback-control system is used. Many of the TEAtime attributes have been realized in TEAPC, as well as many more.

TEAPC demonstrates: operation at better-than-worst-case performance levels, adaptation to varying environmental and CPU loading conditions, disaster

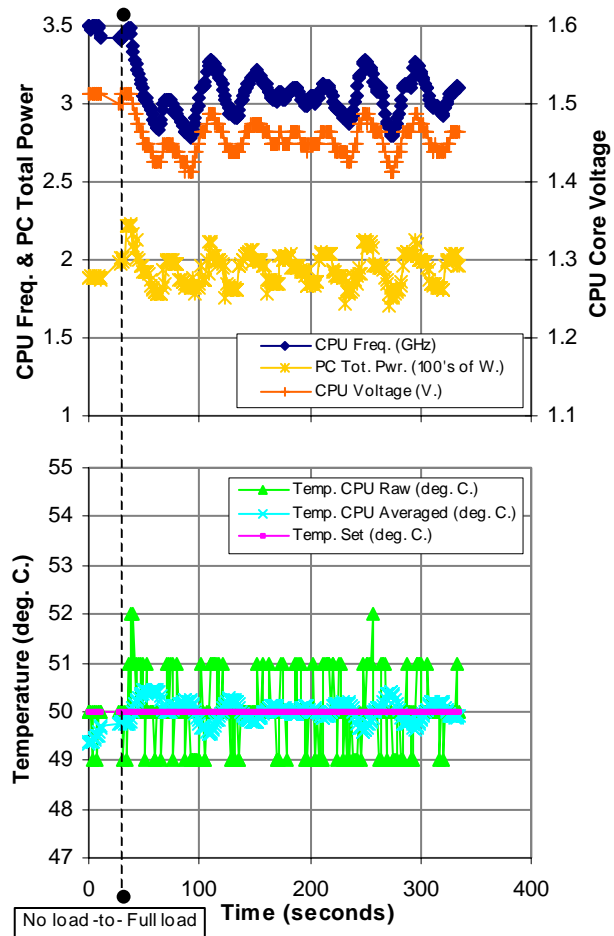

Figure 9. Load adaptation test. Vcore IS linked to CPU frequency.

tolerance, and low-power/high reliability operation. We feel TEAPC could open the way for much more versatile and cost-saving PCs, in many cases those that already exist. Underclocking is a great tool to help achieve several of these features.

## References

- [1] T. D. Burd, T. A. Pering, A. J. Stratakos, and R. W. Brodersen, "A Dynamic Voltage Scaled Microprocessor System," *IEEE JSSC*, vol. 35, no. 11, pp. 1571-1580, November 2000.
- [2] D. Ernst, N. S. Kim, S. Das, S. Pant, R. Rao, T. Pham, C. Ziesler, D. Blaauw, T. Austin, K. Flautner, and T. Mudge, "Razor: A Low-Power Pipeline Based on Circuit-Level Timing Speculation," in *Proceedings of the 2003 International Symposium on Microarchitecture*. San Diego, Calif., USA: IEEE, ACM, December 2003.

[3] G. F. Franklin, M. L. Workman, and D. Powell, *Digital Control of Dynamic Systems*, 3rd ed: Prentice-Hall, 1997.

[4] T. Kuroda, K. Suzuki, S. Mita, T. Fujita, F. Yamane, F. Sano, A. Chiba, Y. Watanabe, K. Matsuda, T. Maeda, T. Sakurai, and T. Furuyama, "Variable Supply-Voltage Scheme for Low-Power High-Speed CMOS Digital Design," *IEEE JSSC*, vol. 33, no. 3, pp. 454-462, Mar. 1998.

[5] M. Miyazaki, J. Kao, and A. Chandrakasan, "A 175mV Multiply-Accumulate Unit Using an Adaptive Supply Voltage and Body Bias (ASB) Architecture," in *Proceedings of the International Solid-State Circuits Conference (ISSCC)*. San Francisco, CA, USA: IEEE, February 3-7, 2002.

[6] M. Olivieri, A. Trifiletti, and A. De Gloria, "A Low-Power Microcontroller with On-Chip Self-Tuning Digital Clock Generator for Variable-Load Applications," in *Proc. of the 1999 International Conference on Computer Design: IEEE*, 1999.

[7] E. Rohou and M. Smith., "Dynamically Managing Processor Temperature and Power," in *Proc. 2nd ACM Wkshp Feedback-Directed Optimiz. (FDDO-2)*. Haifa, Israel: ACM, Nov. 1999.

[8] A. E. Sjogren and C. J. Myers, "Interfacing Synchronous and Asynchronous Modules Within a High-Speed Pipeline," in *Proc. 17th Conference on Advanced Research in VLSI*, 1997, pp. 47-61.

[9] K. Skadron, T. Abdelzaher, and M. R. Stan, "Control-Theoretic Techniques and Thermal-RC Modeling for Accurate and Localized Dynamic Thermal Management," in *Proc. of the 2002 International Symp. on High-Performance Computer Architecture*. Cambridge, MA, USA: IEEE, 2002.

[10] K. Skadron, M. R. Stan, W. Huang, S. Velusamy, K. Sankaranarayanan, and D. Tarjan, "Temperature-Aware Microarchitecture," in *Proceedings of the 30th International Symposium on Computer Architecture*. San Diego, CA, USA: IEEE and ACM, June 2003.

[11] A. K. Uht, "Achieving Typical Delays in Synchronous Systems via Timing Error Tolerant," Department of Electrical and Computer Engineering, University of Rhode Island, Kingston, Technical Report 032000-0100, March 10, 2000.

[12] A. K. Uht, "Uniprocessor Performance Enhancement Through Adaptive Clock Frequency Control," in *Proc. SSGRR-2003w International Conf. on Advances in Infrastructure for e-Business, e-Education, e-Science, e-Medicine, and Mobile Technologies on the Internet*. L'Aquila, Italy: Telecom Italia, January 6-12, 2003.

[13] A. K. Uht, "Going Beyond Worst-Case Specs with TEAtime," *Computer*, vol. 37, no. 3, pp. 51-56, March 2004.

[14] A. K. Uht, "Uniprocessor Performance Enhancement through Adaptive Clock Frequency Control," *IEEE Transactions on Computers*. In press.

[15] R. J. Vaccaro, *Digital Control: A State-Space Approach*: McGraw-Hill, 1995.

**Table 3. Some possible operating scenarios.**

Goal	Tset
<b>Comments</b>	
Lowest power, highest reliability	Low
Frequency and CPU core voltage are minimized, minimizing power consumption and maximizing reliability. Suitable for web browsing (even with broadband access), email and casual use. Could be the normal setting for nighttime operation in an office, to minimize operating costs yet provide the reliability of "always on" operation.	
Mid-range power, reliability	Mid-range
Frequency and core voltage change to maintain a constant CPU temperature equal to the Tset value. Power could still be low, with high reliability. More computationally-demanding tasks could be run, with negligible delay, e.g., limited animation, large Excel worksheets, etc.	
Highest performance	High: frequency is pegged at its maximum value
In the case of the prototype, this would be a case of limited overclocking. Reliability is minimized and power maximized, but performance is also maximized. Useful for intensive computational tasks, such as FPGA net routing, or game playing. (The maximum frequency could also be set for no overclocking.) Could also be the daytime setting in an office, so as to minimize response time during working hours.	
Disaster tolerance	Any
For all practical purposes, TEAPC is always enabled for disaster tolerance.	
Environment change tolerance	Any
With high ambient temperatures TEAPC adapts the system so as to keep the CPU temperature within specifications. Performance is limited, but the system still functions. Conversely, with low ambient temperatures the more favorable conditions can give improved performance.	